

## Rauchgas-Absaugbrenner Fume-Extraction-Torch



### Technische Daten: RGA 400 G

Belastung: 400A CO<sub>2</sub> (nach EN 60 974-7)  
350 A ArCO<sub>2</sub> / M21  
Einschaltdauer: @ 60%  
Draht-ø: 0,8 - 1,6 mm

### Artikel Nr. / Einzelheiten

	3 m	4 m	5 m
Standard-ZA	7090003	7090004	7090005
Federpins-ZA	7090203	7090204	7090205

### Technical Data: RGA 400 G

Rating: 400 A CO<sub>2</sub> (accor. to EN 60 974-7)  
350 A ArCO<sub>2</sub> / M21  
Duty Cycle: @ 60%  
Wire Diameter: 0.8 - 1.6 mm

### Part Number / Details

	3 m	4 m	5 m
Standard Plug	7090003	7090004	7090005
Spring Loaded Pins	7090203	7090204	7090205

# Rauchgas-Absaugbrenner

## Fume-Extraction-Torch

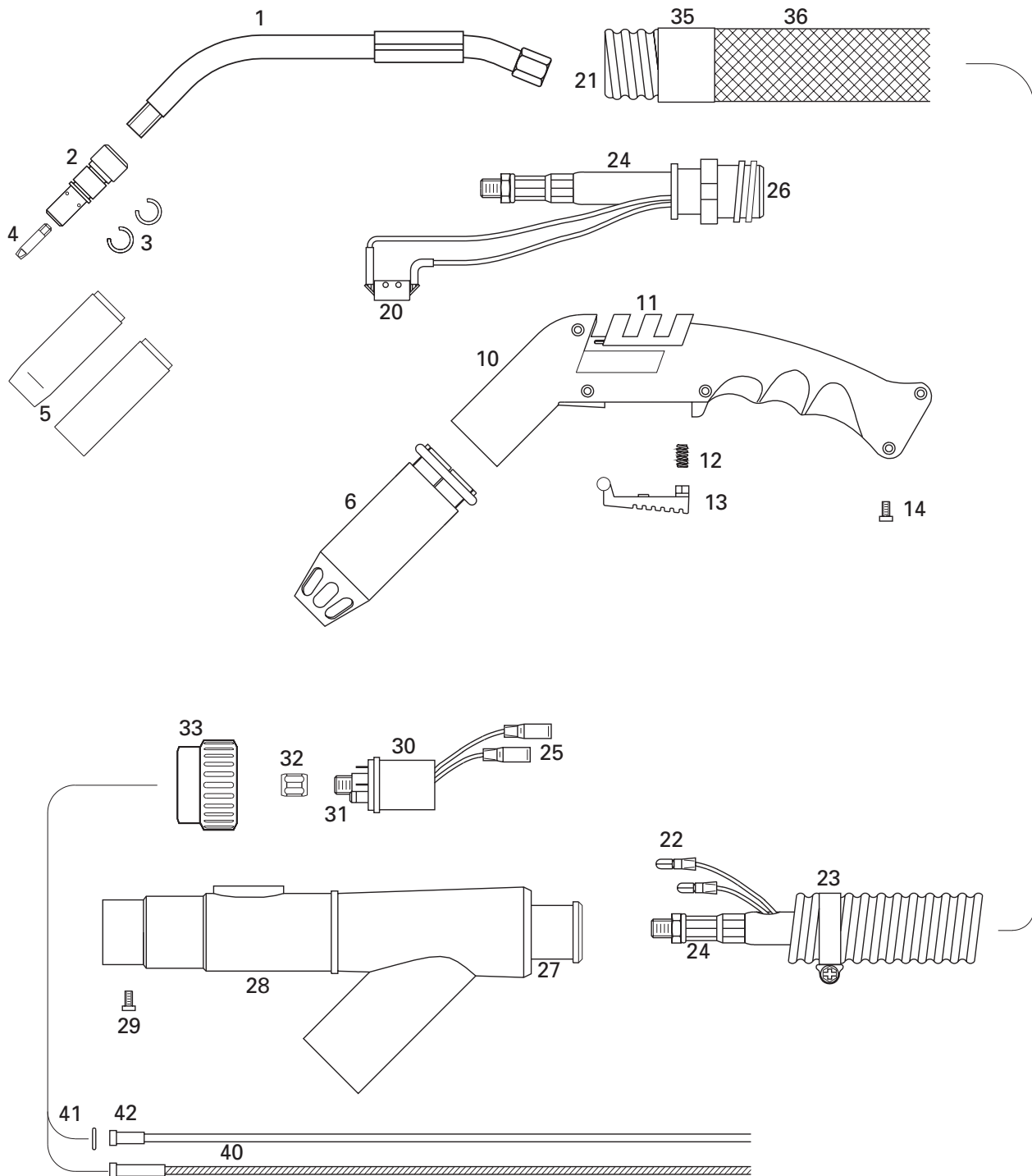

1	Brennerbauteile Torch Components	Brennerhals RGA 400 G Torch Body RGA 400 G	7090100
2		Düsenstock RGA 400 G Tip Adapter RGA 400 G	7090408
3		Federring Metal Ring	ARS010044
4	Kontaktdüsen Contact Tips	Kontaktdüse 0,8 mm Contact Tip D. 0.8 mm Kontaktdüse 1,0 mm Contact Tip D. 1.0 mm Kontaktdüse 1,2 mm Contact Tip D. 1.2 mm Kontaktdüse 1,6 mm Contact Tip D. 1.6 mm Kontaktdüse Alu 0,8 mm Contact Tip D. Alu 0.8 mm Kontaktdüse Alu 1,0 mm Contact Tip D. Alu 1.0 mm Kontaktdüse Alu 1,2 mm Contact Tip D. Alu 1.2 mm Kontaktdüse Alu 1,6 mm Contact Tip D. Alu 1.6 mm Kontaktdüse CuCrZr 0,8 mm Contact Tip D. CuCrZr 0.8 mm Kontaktdüse CuCrZr 1,0 mm Contact Tip D. CuCrZr 1.0 mm Kontaktdüse CuCrZr 1,2 mm Contact Tip D. CuCrZr 1.2 mm Kontaktdüse CuCrZr 1,6 mm Contact Tip D. CuCrZr 1.6 mm	ARS061008 ARS061010 ARS061012 ARS061016 ARS661008 ARS661010 ARS661012 ARS661016 ARS761008 ARS761010 ARS761012 ARS761016
5	Gasdüsen Gas Nozzles	Gasdüse zylindrisch Gas Nozzle cylindrical Gasdüse konisch Gas Nozzle conical	ARS080011 ARS081012
6		Absaugdüse RGA 400 G Fume Extraction Nozzle RGA 400 G	7090800
10		Handgriff linke + rechte Hälfte Handle, left and right Half	6961001
11		Bypass-Schieber Vent-Control	6961003
12		Schalterfeder Trigger-Spring	6161106

13		Drücker Trigger	6961002
14		Schraube Screw	0040801
20		Mikroschalter Micro-Switch	6161105
<hr/>			
21		Wellschlauch - 3 m Flexible-Cover-Hose 3 m	2924530
		Wellschlauch - 4 m Flexible-Cover-Hose 4 m	2924540
		Wellschlauch - 5 m Flexible-Cover-Hose 5 m	2924550
22		Rundstecker, isoliert Male Electrical Connector, insulated	2155200
23		Schlauchklemme Hose-Clamp	2911900
<hr/>			
24	Koaxialkabel Coaxial Cable	50 mm <sup>2</sup> , 3 m	3005030
		50 mm <sup>2</sup> , 4 m	3005040
		50 mm <sup>2</sup> , 5 m	3005050
<hr/>			
25		Rundsteckbuchse, isoliert Female Electrical Connector, insulated	2155100
26		Verbindungsstück vorne Front-Swivel-Connector	6961200
27		Schlauchanschluss hintern Rear-Swivel-Connector	2921700
28		Verteiler RGA Rear-Extraction-Chamber	2921600
29		Schraube Screw	0040601
30		ZA-Stecker, luft Gun Plug Body, air cooled (EURO)	2151500
		ZA-Stecker mit Federpins Gun Plug Body with Spring Loaded Pins	2151505
31		O-Ring O-Ring	0041000
32		Ms-Überwurfmutter Liner Positioner Nut	2151501

33	Anschlussmutter Gun Plug Nut	2151700
35	Schrumpfschlauch Heat Shrink Hose	2921206
36	Lederschlauch 1,5 m Leather Hose 1.5 m	2921115
40	DF-Spiralen ummantelt und Teflonseelen Coated Steel- and Teflon-Liners	
	Teflonseele 1,5 x 4,0 mm / 3 m Teflon Liner 1.5 x 4.0 mm / 3m	3411530
	Teflonseele 1,5 x 4,0 mm / 4 m Teflon Liner 1.5 x 4.0 mm / 4 m	3411540
	Teflonseele 1,5 x 4,0 mm / 5 m Teflon Liner 1.5 x 4.0 mm / 5 m	3411550
	Teflonseele 2,0 x 4,0 mm / 3 m Teflon Liner 2.0 x 4.0 mm / 3m	3412030
	Teflonseele 2,0 x 4,0 mm / 4 m Teflon Liner 2.0 x 4.0 mm / 4m	3412040
	Teflonseele 2,0 x 4,0 mm / 5 m Teflon Liner 2.0 x 4.0 mm / 5m	3412050
	DF-Spirale 1,5 x 4,0 mm / 3 m umm., kpl. Coated Steel Liner 1.5 x 4.0 mm / 3m	3441530
	DF-Spirale 1,5 x 4,0 mm / 4 m umm., kpl. Coated Steel Liner 1.5 x 4.0 mm / 4m	3441540
	DF-Spirale 1,5 x 4,0 mm / 5 m umm., kpl. Coated Steel Liner 1.5 x 4.0 mm / 5m	3441550
	DF-Spirale 2,0 x 4,0 mm / 3 m umm., kpl. Coated Steel Liner 2.0 x 4.0 mm / 3m	3442030
	DF-Spirale 2,0 x 4,0 mm / 4 m umm., kpl. Coated Steel Liner 2.0 x 4.0 mm / 4m	3442040
	DF-Spirale 2,0 x 4,0 mm / 5 m umm., kpl. Coated Steel Liner 2.0 x 4.0 mm / 5m	3442050
41	O-Ring 3,5 x 1,5 O-Ring 3.5 x 1.5	0031500
42	Haltenippel für ummantelte Spirale Collet for Coated Liner 4.0	2155645
42	Haltenippel für Teflonseele 4,0 Collet for Teflon Liner 4.0	2155740

## Fehlerbehebung

- |                                |   |
|--------------------------------|---|
| 1.) Schlechter Drahtvorschub:  | Spirale verstopft oder geknickt. Falsche Größe von Spirale oder Stromdüse. Spirale zu kurz und liegt nicht korrekt am Düsenstock an.  |
| 2.) Brennerüberhitzung:        | Lose Verbindung am Zentralanschluß. Brenner wird mit zu hoher Amperezahl geschweißt. Zu gering bemessenes Massekabel.   |
| 3.) Poröse Schweißnaht:        | Spritzer in der Gasdüse behindern den Gasdurchfluß. Lose Verbindung von Gasschlauch oder Leck im Gasschlauch. O-Ringe am Zentralanschluß sind lose oder beschädigt.                         |
| 4.) Kurze Stromdüsenstandzeit: | Drahtvorschubrollen sind zu eng angezogen und verursachen Riefen am Schweißdraht. Der Schweißdraht ist schmutzig oder rostig. Falsche Stromdüsendurchmesser. Brenner wird zu hoch belastet. |

## Trouble Shooting

- |                      |   |
|----------------------|---|
| 1.) Poor Wire Feed:  | Liner clogged or kinked. Incorrect liner size or contact tip. Liner cut too short and not seating properly in tip adapter.  |
| 2.) Gun Overheating: | Loose connection at the wire feeder. Gun being run beyond its amperage. Insufficient gauge power cable or ground cable.   |
| 3.) Weld Porosity:   | Spatter built up in nozzle blocking gas. Leaks in gas hose or improper connection. Conductor tube loose from adapter block or O-Rings at plug are cut or damaged. |
| 4.) Short Tip Life:  | Drive rolls too tight resulting in scoring of weld wire. Welding wire dirty, rusty or too much cast. Wrong tip size. Torch over rated duty cycle.                 |

