





welcome

Welding is the most important and versatile joining technique. In fields where highest quality demands are required, standard solutions are not sufficient anymore.

Especially in the field of pipeline and narrow gap welding spa welding systems gmbh made customer oriented developments and solutions to its business.

This solutions not only perform highest quality demands but also prolong the service live of used tools and guarantee a fast and safe mechanical handling and therefore increase productivity.

Our predominantly international and also national customers in pipeline- , steel- , plant construction and automotive industry appreciate our quickness, flexibility and creativity in our MIG and SAW welding application spectrum.

Here our unique coated current contact tips and gas nozzles achieve extraordinary good economic and ecologic results. This effect is even increased when using our high temperature strong copper alloy DHCA.

For welding hard to access areas our specially developed narrow gap welding system will ease your work.

When welding pipelines you can use our high quality positioning bands (guide rings) which we build for almost any existing automatic orbital welding system including our new designed latch system.

A brand new and unique automatic orbital welding system with an excellent cost/performance ratio just competed our program line and will be launched to the market.

Further more we offer various products in the field of welding technology. The innovative potential of spa welding systems is still growing.

Combination of different materials and a lean structure ensures a fast solution of today's welding problems.

Michael Kett
C.E.O.



article list

Here you will find soon the complete article lists according to our catalog.
We will offer the lists also on our website www.spa-welding.com for downloading.

We can also send you the requested article lists through our online request centre:
www.spa-welding.com

contact datas

fon: 0049/8142/4445990

fax: 0049/8142/4445999

spa welding systems gmbh
Industriestr. 29
82194 Gröbenzell / Munich
Germany

mail@spa-welding.com

www.spa-welding.com



spa makes the weld go round.



spa root purging system

The spa root purging system is designed to protect the inside of the pipe welding seams from oxygen. Especially it is used when welding stainless or DUPLEX steel. Here the pipe will be sealed with the spa root purging system amounting to the weld gap and purged with forming gas. This ensures that the weld seam (root) will be protected from oxygen.

A set of spa root purging system consist of sealing discs made out of a high temperature resistant silicone and aluminium supporting discs assuring a perfect stabilisation and sealing of the silicone discs. Further the spa root purging system has a sintered brass gas diffuser providing a homogenous gas flow.

In combination with a tackle the spa root purging system can be positioned and removed properly and quickly in the pipe. At the other end of the system a small gas distributor guarantees that gas can leak and the gas pressure in the chamber remains constant. Also the weld seam is perfectly shielded against the atmosphere.

The connecting device between the sealing and supporting discs is available in a fixed or flexible version for getting access to pipe elbows.

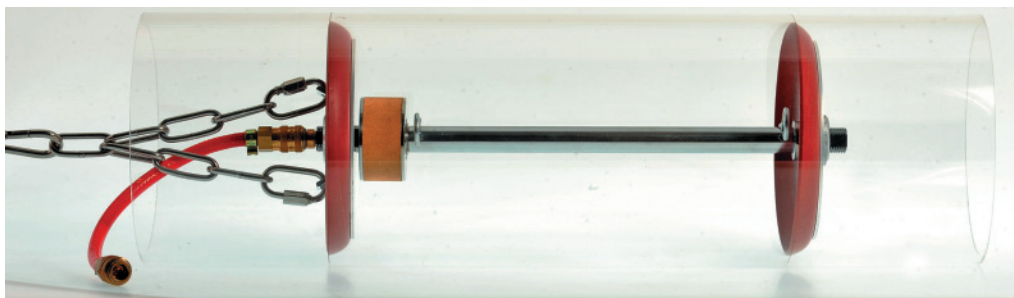

spa root purging system

The spa root purging system offers following advantages:

- highly flexible for different pipe diameters and pipe elbows
- cost effective priced due to modular system
- high durability by high quality of components

The spa root purging system is designed for purging pipes up to a diameter of 500mm (20"). The smallest pipe diameter you can purge is 50mm (2").



spa root purging system

The **spa root purging system** is perfectly applicable in the field of pipewelding – mainly made out of VA and Duplex Steel. In general the welding process will be optimized and insures a welding process stability.

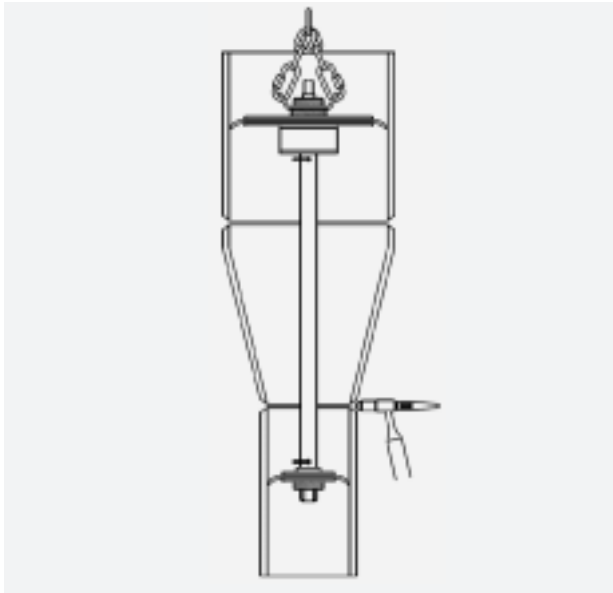

spa root purging system

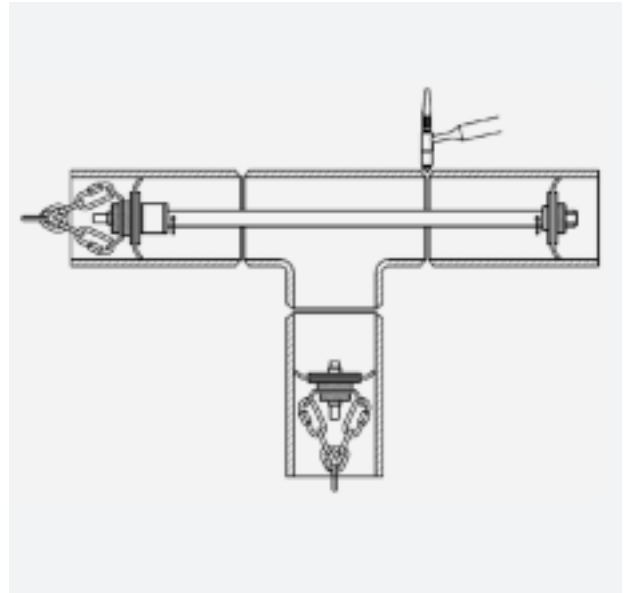

spa root purging system

The spa root purging system offers following advantages:

- ease of operation
- covers pipe diameters from 50mm (2") to 500mm (20")
- highly flexible for different pipe diameters and pipe elbows
- cost effective priced due to modular system
- high durability by high quality of components
- quick installation and removal ensured

The spa root purging system is designed for purging pipes up to a diameter of 500mm (20"). The smallest pipe diameter you can purge is 50mm (2").

To guarantee a perfect fitting of the system, the out diameter of the sealing discs shall be 10mm (0.39") and the supporting discs shall be 20mm (0.79") smaller than the pipe inside diameter.